

# RECARO

## SITTING SAFELY TO WIN SAFELY

The RECARO racing seats for motorsport





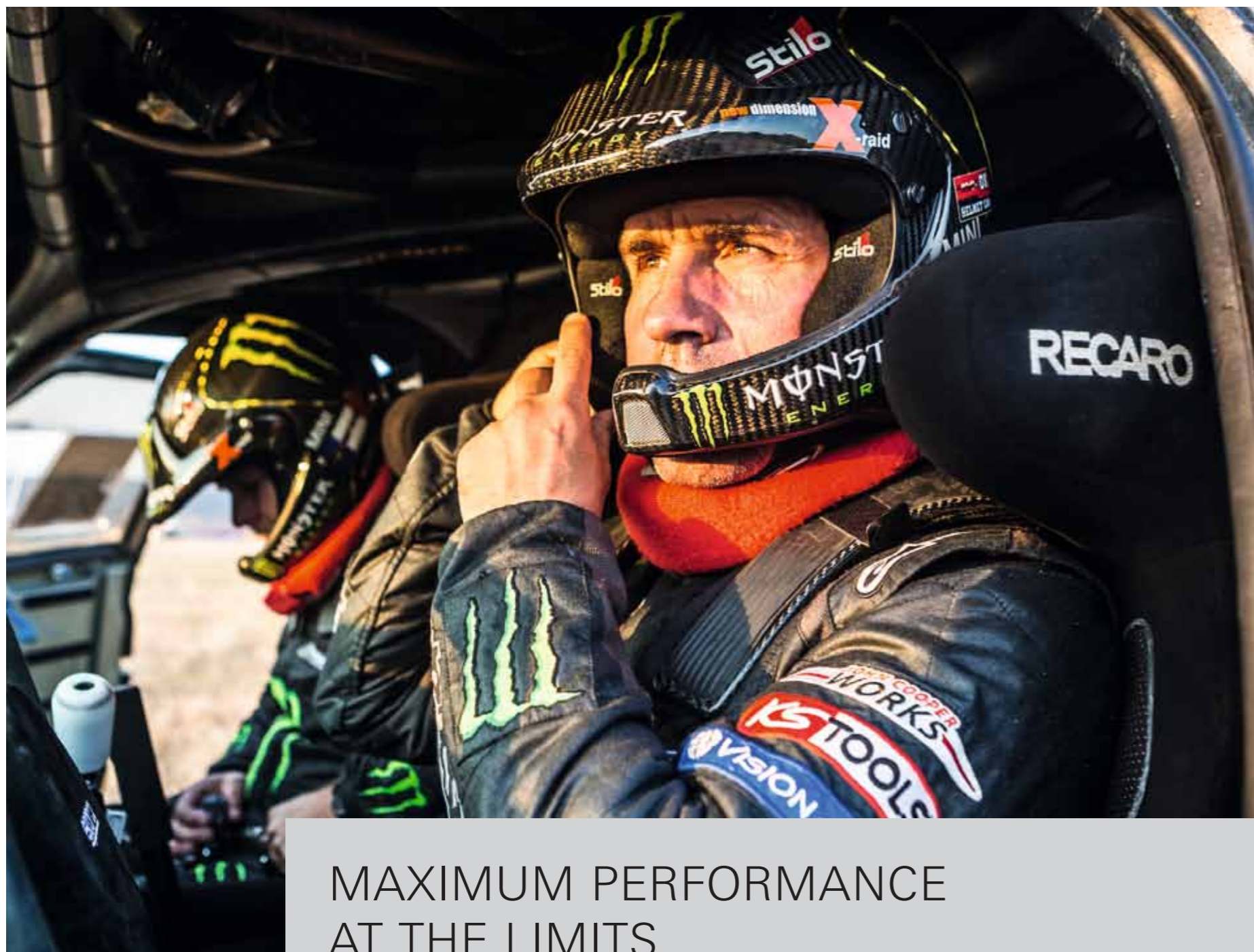

## MAXIMUM PERFORMANCE AT THE LIMITS

Ingenious Design by RECARO



Motorsport – it's all about the toughest tests of driver and material. High speeds, centrifugal forces, vibrations, jumps, impacts, maximum braking. Those looking for success in motorsport must be able to rely on their equipment. One hundred percent. No ifs, ands, or buts.

For RECARO Automotive Seating, ingenious design in motor sports means the combination of safety, ergonomics, comfort and quality – for us, compromises are out of the question. At RECARO, one thing always stands at the center of everything we do: people. Based on you and your requirements as a semi-professional or professional racing driver, we have developed a program for racing seats, which we present on the following pages – the reference work for sitting optimally in racing vehicles.

Ingenious design is an indispensable part of our heritage, our "brand DNA." This claim was born in the course of our more than 100 years of company history, and has grown up with a constant stream of new ideas. That means: innovation from tradition. As we see it, design goes far beyond the basic meaning of the word: it encompasses every single step on the way to the RECARO racing seat. Innovative concepts, materials, shapes and processing methods ensure that your RECARO experience is always a very special one.

On the racetrack, offroad in a rally car or on long-distance races – winners rely on RECARO.





## NO COMPROMISES BOUNDLESS TRUST

For over 40 years

Experience pays off. We started developing seats for motor racing about 40 years ago. It's a challenging task to which we dedicate our full know-how and innovative power as seat experts. Because motorsport is about one thing above all others – providing protection for the human body and the best-possible support. Each second on the race track demands maximum concentration and total awareness. The best racing seat is the one the driver hardly notices. Because it holds and supports him naturally, like a second protective skin.

The safety provided by the racing seats from RECARO Automotive Seating can not only be felt. It is also tested, proven and confirmed under the hardest of conditions. Our products meet the high requirements of the FIA in all disciplines. The FIA approval applies to the entire system (RECARO racing seat in conjunction with specified sidemount).

We are also the first and only manufacturer to offer independently tested seats and sidemounts that permit both rigid mounting and solutions with fore-aft adjustment. Our latest products, the RECARO Pro Racer Ultima XL and the RECARO P 1300 GT, have been approved for ten years in accordance with the new FIA standard 8862-2009 for Advanced Racing Seats.

As a seat specialist with 40 years of motorsport experience, RECARO supports the "FIA Action for Road Safety" for safe seating comfort on all racing circuits.





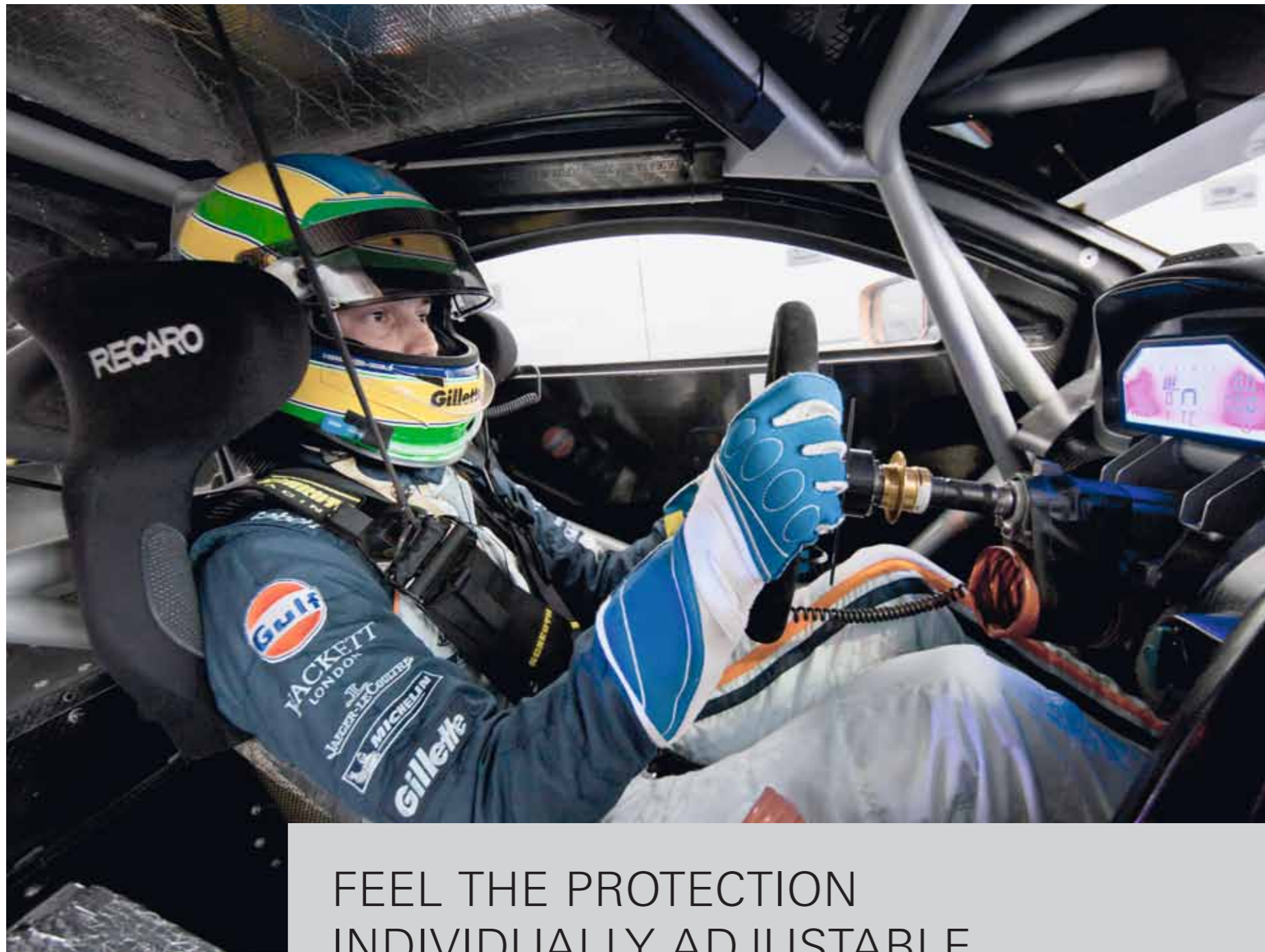

## FEEL THE PROTECTION INDIVIDUALLY ADJUSTABLE

Comfortable and modular



A racing car isn't comfortable. It's loud, hard, reduced to the essentials. As the interface between human and machine, the seat gives the driver direct feedback in each thousandth of a second – about the chassis, tires, brakes, engine, and road quality. And is at the same time so customized that the driver can concentrate on the race without restriction.

At RECARO, we make this possible with our combined knowledge of the human anatomy and in particular the spine. Our racing seats are ergonomically designed to provide the best-possible protection for the back as well as optimal support against all the forces the back has to endure while maintaining posture.

We supplement this basic comfort with features such as replaceable pads in three different sizes. Individual comfort requirements can therefore be adjusted in no time at all. Another plus point: the pads do not cover the entire seat, but are targeted solely at the contact points with the body. That permits passive air conditioning of the seat, allowing the air to circulate. Our modular system also has shells that can be optionally mounted with a rigid or flexible sidemount. The latter permits fore-aft adjustment inside the vehicle. Both comfort seats are ideal for racing use with frequent and fast changes of driver. The adapter's maximum rigidity ensures practically no movement from the seat itself and gives you as the driver totally direct feedback on every driving situation. It is thus the feel from the 'seat of your pants' that is key to good lap times and race success.





## THE PATH TO YOUR RECARO SEAT

Your totally personal RECARO seat experience in the cockpit is just a few steps away. Take your time – and begin by asking yourself a few questions: In which racing series (semi-professional/professional) will the seat be used? Which FIA standard must it fulfill? Must it be compatible for HANS systems? As a single driver, do I need a seat with a rigid sidemount or is the seat intended for a team with frequent changes of driver? Which material – ultra-light carbon or conventional glass fiber reinforced plastic – will I opt for with regard to the factors of weight and cost?

1

### Step 1 – Information: Which RECARO racing seat is the right one for me?

Find full details about the current product range of racing car seats in this brochure, online at [www.recaro-automotive.com](http://www.recaro-automotive.com) under Seatfinder Motorsport, or in the showroom at one of our authorized RECARO partners (online under Dealer search). That's the first step to finding which RECARO model is your dream seat and how it meets your personal requirements.

2

### Step 2 – Decision: How do I configure my RECARO seat?

For a balanced decision, we always recommend you seek personal advice from an authorized partner. It can often provide just the solutions you need to meet your personal requirements. Trying out all the features of your preferred seat in depth should complete your visit to the showroom.

You can also select your racing seat online at [www.recaro-automotive.com](http://www.recaro-automotive.com). To do this, click on the Seatfinder Motorsports under the Motorsport menu and select your preferred features. Clicking directly on one of the selected seats will give you detailed information about it. Please note that special sidemounts are required to install RECARO racing seats. Only in the correct combination is your RECARO racing seat perfectly combined with the racing car – only then will the FIA approval apply.

You should also learn about the technical requirements of your vehicle and, if necessary, the installation dimensions of your vehicle. This brochure contains the technical specifications of our product range.

3

### Step 3 – Order: How do I order my RECARO seat?

Ideally, you should order your RECARO racing seat direct from your authorized partner. It will check your product choice, match the technical prerequisites and also order the complete scope of delivery, including baseframes, sidemounts, etc., for you from RECARO. Your RECARO will then be delivered to the service partner as a ready-to-install package.

4

### Step 4 – Installation: How is the racing seat fitted into my car?

You should have your RECARO racing seats installed only by a qualified and authorized partner.

## GUARANTEED FIA APPROVED



All RECARO racing seats are approved as complete systems (RECARO racing seats in conjunction with rigid or flexible sidemounts) to the high requirements of the FIA. **Under the new FIA 8862-2009 standard, the systems are tested with forces that are 4.6 times greater!**

### FIA 8855-1999

**Validity:**  
Approval valid for five years.

**Scope:**  
Racing seat plus rigid sidemount.

**Type of tests:**  
Exclusively dynamic tests

- 1. Rear impact 20 g with dummy 50% (75 kg):**  
Test with dummy, backward 20 g over 50 ms
- 2. Side impact 15 g with dummy 50% (75 kg):**  
Test with dummy, forward and backward 15 g over 50 ms
- 3. Rear impact 10 g with dummy 50% (75 kg):**  
Test with dummy, backward 10 g over 50 ms

### FIA 8862-2009 (Advanced Racing Seat)

**Validity:**  
Approval applies for ten years, already introduced for WRC; in future also for FIA world championships GT and WTCC.

**Scope:**  
Seat substructures including rigid and flexible sidemounts are approved as part of the seat system.

**Type of tests:**  
Change from dynamic to quasi-static tests in order to ensure controlled, dosable loads, exact, reproducible test arrangements, and precise results.

Much greater test requirements – increased by around 300% – for rear impact and side impact, specially in the pelvis, shoulder and head areas of the racing seat.

Three consecutive tests with forces of between a total of 32 kN (approx. 3.3 metric tons) and 60 kN (approx. 6.1 metric tons):

- 1. Static load test** (against direction of travel):  
14 kN with max. movement at pelvis,  
14 kN with max. movement at shoulder,  
7 kN with max. movement at headrest
- 2. Side load test:**  
14 kN with max. movement at pelvis,  
11 kN with max. movement at shoulder,  
7 kN with max. movement at headrest
- 3. Compression test:**  
Seat must absorb energy of 1 kJ, whereby the applied later load must not exceed 30 kN and the specified inward deformation of the seat must not exceed 200 mm; backward 10 g over 50 ms.

RECARO ASSEMBLY KIT



RECARO racing seat



Rigid sidemount



Flexible sidemount

Whatever you decide, you're sure to be in pole position when it comes to your choice of seat – we wish you safe racing at all times and lots of success!



PROFESSIONAL RACING SEATS

SEMI-PROFESSIONAL RACING SEATS

OVERVIEW  
SEAT RANGE  
RACING SEATS

	RECARO P 1300 GT	RECARO Pro Racer Ultima 1.0	RECARO Pro Racer Ultima XL	RECARO Pro Racer SPG & SPA	RECARO Pro Racer SPG & SPA XL	RECARO Profi SPA	RECARO Profi SPG & SPG XL	RECARO Apex	RECARO Pole Position (FIA)	RECARO Furious
USE*	For GT vehicles	●			●	●			●	●
	For touring vehicles	●			●				●	●
	For rally vehicles		●	●			●	●		
COMFORT	Flexible sidemount	●			●					
	Rigid sidemount	●	●	●	●			●	●	●
	Seat in XL version			●	●		●			●
	Anatomical seat contour	●	●	●	●		●	●	●	●
	Replaceable pads (S, M, L)	●	●	●	●					
LIGHTWEIGHT	Seat shell glass fiber reinforced plastic (GRP)				●			●	●	●
	Seat shell carbon/Carbon-Kevlar® (CFRP)	●	●	●	○		●			●
	Weight: complete shell (incl. foam and upholstery, without sidemount)	approx. 14.7 kg	approx. 12.7 kg	approx. 13.2 kg	SPG: approx. 9.0 kg SPA: approx. 7.0 kg	SPG XL: approx. 10.0 kg SPA XL: approx. 7.5 kg	approx. 5.5 kg	SPG: approx. 7.0 kg SPG XL: approx. 10.0 kg	approx. 7.0 kg	approx. 7.5 kg
SAFETY	FIA 8862-2009 (Advanced Racing Seat)	●	●	●						
	FIA 8855-1999				●					●
	FIA approval for 10 years	●	●	●						
	Upholstery tested for flame-retardance to FMVSS 302				●					●
	Upholstery tested for flame-retardance to ISO 3795	●	●	●	●					●
	Suitable for 4-, 5- or 6-point belts	●	●	●	●					●
	Shock-absorbent foam	●	●	●	●					●
Suitable for HANS systems	●	●	●	●						

● Standard features, ○ options (additional charge)  
\* Recommend use for racing series





## ULTIMATE RELIABILITY IN EXTREME CONDITIONS

The RECARO racing seats to FIA 8862-2009  
(Advanced Racing Seat)

As a professional motorsport driver, you move at the limits in every respect: You are under extreme tension and exposed to extreme loads. RECARO racing seats offer you the performance you need on your journey to success: with maximum safety, optimal hold, and absolutely reliable quality. Independently tested for ten years according to the new, stricter FIA standard for "Advanced Racing Seats."





# THE SEATS FOR WINNERS

The world innovation for professional motorsport with the license to win: its combination of maximum safety and individual comfort is what makes our new RECARO P 1300 GT so unique. It is the first racing seat in the world to conform to the new FIA 8862-2009 standard for "Advanced Racing Seats" and comes with fore-aft adjustment thanks to the flexible sidemount. With its replaceable pads in three sizes and the flexible sidemount, it gives drivers maximum personalization options. It is ideally suited for racing use with frequent and fast changes of driver. The RECARO P 1300 GT is approved exclusively for use in GT and touring car sport.



**Raeder Motorsport**  
 "We prefer racing seats that provide not only top levels of safety, but comfort too. Both are perfectly combined in RECARO's P 1300 GT: thanks to the extremely stable lengthways adjustment function, it's the ideal seat for endurance races with alternating drivers. Sitting in the shell, each driver has maximum contact with the vehicle - and thus with the track as well."  
 Martin and Nicolas Raeder, team manager

## // RECARO P 1300 GT

### Standard features

- + Certified according to FIA 8862-2009 (Advanced Racing Seat)
- + Seat shell made of carbon fibre
- + Developed for the use of HANS systems
- + Suitable for 4-, 5- or 6-point belts
- + Head protector
- + Shock-absorbing foam
- + Highly flame-retardant upholstery
- + Replaceable pads:  
 Pad Kit M for drivers of medium build (standard feature)
- + FIA approval for 10 years

### Accessories

- + Flexible sidemount RECARO P 1300 GT ideal for races with driver changes (130 mm fore-aft adjustment, tilt angle can be varied by max. 3° during installation)
- + Rigid sidemount RECARO P 1300 GT
- + Pad Kit S: Replaceable pads for drivers of small build
- + Pad Kit L: Replaceable pads for drivers of large build
- + Lumbar pad
- + Side support pad

### Weight

approx. 11.4 kg (without pads/upholstery)  
 approx. 14.7 kg (with pads/upholstery)

### Pad Kit S, M, L



### FIA 8862-2009 (Advanced Racing Seat)\*



### Upholstery variant



Velour black

### Accessories



Flexible sidemount RECARO P 1300 GT

Rigid sidemount RECARO P 1300 GT

Pad Kit S, 6-piece, without seat cushion

Pad Kit L, 5-piece, without seat cushion

Lumbar pad

Side support pad

Photo shows options



**PORSCHE**  
**MOTORSPORT**

OFFICIAL SUPPLIER

**RECARO**

RECARO P 1300 GT is designed for vehicles with a slope angle of 8.5°. This is the only way to enable the tilt setting of 3° during installation.  
 \* FIA approval 8862-2009 (Advanced Racing Seat) only in conjunction with specified sidemounts.



# THOROUGHbred RALLY PROFESSIONAL

Ultimate safety to the newest standard, approved for ten years: The RECARO Pro Racer Ultima 1.0 made from high-strength, lightweight carbon material is particularly suited for use in professional rallying. Replaceable pads and an optional lumbar pad permit individual adjustment to different body sizes and comfort requirements. FIA approved, including sidemount, to 8862-2009 (Advanced Racing Seat).



**Hermann Gassner jr.:**  
 "Gassner and RECARO, they just go together! From the very start of my career I've put my faith in RECARO racing seats – and that's not going to change, either. In addition to the fantastic safety, the ride comfort is also absolutely unbeatable."  
 Hermann Gassner jr., rally driver



Photo shows options

## // RECARO Pro Racer Ultima 1.0

### Standard features

- + Certified according to FIA 8862-2009 (Advanced Racing Seat)
- + Seat shell made of carbon fibre
- + Developed for the use of HANS systems
- + Suitable for 4-, 5- or 6-point belts
- + Head protector
- + Shock-absorbing foam
- + Highly flame-retardant upholstery
- + Replaceable pads:  
 Pad Kit M for drivers of medium build (standard feature)
- + FIA approval for 10 years

### Accessories

- + FIA approved sidemount
- + Pad Kit S: Replaceable pads for drivers of small build
- + Pad Kit L: Replaceable pads for drivers of large build
- + Lumbar pad

### Weight

approx. 10.6 kg (without pads/upholstery)  
 approx. 12.7 kg (with pads/upholstery)

### Pad Kit S, M, L



FIA 8862-2009 (Advanced Racing Seat)\*



### Upholstery variant



Velour black

### Accessories



Steel sidemount



Pad Kit S, 6-piece, without seat cushion

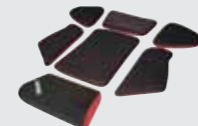

Pad Kit L, 7-piece, with seat cushion



Lumbar pad

\* FIA approval 8862-2009 (Advanced Racing Seat) only valid in conjunction with the specified sidemount.





# XL COMFORT AND SAFETY

New – the RECARO Pro Racer Ultima XL, including the sidemount, is also approved according to FIA standard 8862-2009 (Advanced Racing Seat). The racing seat is 20 mm wider than the RECARO Pro Racer Ultima 1.0 and also offers the same features and functions, such as replaceable pads and an optional lumbar pad.



**Ken Block**  
 "I love my RECARO seats. After a bad crash in the World Rally Cup in Portugal I was very glad that I had the RECAROs. The seat was one of the main reasons that I survived the crash without a scratch."  
 Ken Block, rally driver



Photo shows options

## // RECARO Pro Racer Ultima XL

### Standard features

- + Certified according to FIA 8862-2009 (Advanced Racing Seat)
- + 20 mm wider than RECARO Pro Racer Ultima 1.0
- + Seat shell made of carbon fibre
- + Developed for the use of HANS systems
- + Suitable for 4-, 5- or 6-point belts
- + Head protector
- + Shock-absorbing foam
- + Highly flame-retardant upholstery
- + Replaceable pads:
  - Pad Kit M for drivers of medium build (standard feature)
- + FIA approval for 10 years

### Accessories

- + FIA approved sidemount
- + Pad Kit S: Replaceable pads for drivers of small build
- + Pad Kit L: Replaceable pads for drivers of large build
- + Lumbar pad

### Weight

approx. 9.8 kg (without pads/upholstery)  
 approx. 13.2 kg (with pads/upholstery)

### Pad Kit S, M, L



FIA 8862-2009 (Advanced Racing Seat)\*



### Upholstery variant

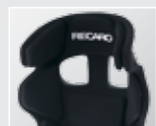

Velour black

### Accessories



Steel sidemount



Pad Kit S, 6-piece, without seat cushion

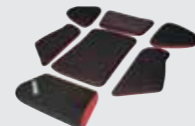

Pad Kit L, 7-piece, with seat cushion



Lumbar pad

\* FIA approval 8862-2009 (Advanced Racing Seat) only valid in conjunction with the specified RECARO sidemount.





## SAFE FROM THE START SAFE AT THE DESTINATION

The RECARO racing seats to FIA 8855-1999

Get into semi-professional and professional motorsport without making any compromises: Unique design, materials of the highest standard and excellent methods of manufacture give our RECARO racing seats their outstanding product qualities.



# FOR PROS WITH A CLAIM TO WINNING

Our top product for GT and touring car sport to FIA 8855-1999 – the RECARO Pro Racer was developed for the use of HANS systems and is available in four variants.

They differ on the one hand through the seat material – glass fiber reinforced plastic (GRP) or carbon composite (CFRP) – and on the other through the size: the optional XL version is both wider and higher. New is the FIA approved flexible sidemount for fore-aft adjustment, which offers the driver even more individual adjustment options.

## // RECARO Pro Racer SPG & SPA

### Standard features

- + Developed for the use of HANS systems
- + Suitable for 4-, 5- or 6-point belts
- + Head protector
- + Shock-absorbing foam
- + Flame-retardant upholstery
- + Friction grip surface around the shoulders

### Accessories

- + Steel sidemount
- + Aluminum sidemount
- + Flexible sidemount ideal for races with change of driver
- + Seat cushion

### RECARO Pro Racer SPG & XL

- + Seat shell made of glass fiber reinforced plastic (GRP)
- + **XL:** Seat shell 35 mm wider and 35 mm higher

### RECARO Pro Racer SPA & XL

- + Seat shell in Carbon-Kevlar® composite (CFRP)
- + **XL:** Seat shell 35 mm wider and 35 mm higher

### Weight

Pro Racer SPG: approx. 9.0 kg  
Pro Racer SPG XL: approx. 10.0 kg

Pro Racer SPA: approx. 7.0 kg  
Pro Racer SPA XL: approx. 7.5 kg

### FIA 8855-1999\*



### Upholstery variant



Velour black

### Accessories



Flexible sidemount Pro Racer SPG/SPA

Flexible sidemount Pro Racer SPG/SPA XL

Pro Racer SPG & SPA: Steel sidemount

Pro Racer SPG XL: Steel sidemount

Pro Racer SPA XL: Aluminum sidemount

Pro Racer SPG & SPA: High seat cushion Height 55 mm



**Timo Bernhard**

"The RECARO Pro Racer racing seat gives me just the amount of comfort that I need in a race vehicle. What's key is that I have complete side support in order to deliver top performance. And on top of that the RECARO gives me the necessary safety."

Timo Bernhard, professional racing driver



Photo shows options



\* FIA approval 8855-1999 only valid in conjunction with the specified RECARO sidemount.



# PREMIUM HOLD IN ALL LOCATIONS

Ideal for offroad and rally use – the professional shell of the RECARO Profi SPG (glass fiber reinforced plastic) and SPA (carbon composite) has been proven on thousands of occasions and offers superb lateral hold on an off the racetrack. The XL variant of the seat is not only wider and higher, but also has larger belt slots.

## // RECARO Profi SPG & SPA

### Standard features

- + Suitable for 4-, 5- or 6-point belts
- + Shock-absorbing foam
- + Flame-retardant upholstery
- + Friction grip surface around the shoulders
- + Screw-mounted panels on the belt slots

### Accessories

- + Steel sidemount
- + Aluminum sidemount
- + Seat cushion

### RECARO Profi SPG & XL

- + Seat shell made of glass fiber reinforced plastic (GRP)
- + **XL:** Larger belt slots
- + **XL:** Seat shell 35 mm wider and 50 mm higher

### RECARO Profi SPA

- + Seat shell in Carbon-Kevlar® composite (CFRP)
- + Pronounced lateral support as Profi SPG
- + Specially formed shoulder support

Weight
Profi SPG: approx. 7.0 kg Profi SPG XL: approx. 10.0 kg
Profi SPA: approx. 5.5 kg
FIA 8855-1999*



### Upholstery variants



Velour black      Velour red

### Accessories



Profi SPG & SPA: Steel sidemount      Profi SPG XL: Aluminum sidemount



**Walter Röhrl**  
 "Over the 40 years of my motorsport career, I've always driven safely, well and successfully in a RECARO seat – and that's how it'll be in the future, too!"  
 Walter Röhrl, rallying legend



Photo shows options

\* FIA approval 8855-1999 only valid in conjunction with the specified RECARO sidemount.



# FOR START TO FINISH VICTORIES

As its name suggests, the RECARO Pole Position (FIA) racing seat provides the best conditions for all beginners and professionals who want to battle for a place on the podium from pole position. Its generous features and numerous individualization options for cushions and upholstery make it the popular favorite in GT, touring car and club sport.



**Karolina Pilarczyk**  
 "I used the RECARO racing seats throughout the 2014 drift season. They're perfect! I felt as one with the vehicle! They're not only safe, but also very comfortable."  
 Karolina Pilarczyk, drift driver



Photo shows options

## // RECARO Pole Position (FIA)

### Standard features

- + Seat shell made of glass fiber reinforced plastic (GRP)
- + Suitable for 4-, 5- or 6-point belts
- + Flame-retardant upholstery
- + Screw-mounted panels on the belt slots
- + Seat and backrest cushions replaceable
- + Lumbar cushions

### Accessories

- + Steel sidemount

<b>Weight</b>
approx. 7.5 kg
<b>FIA 8855-1999*</b>



### Upholstery variants



Velour black    Velour blue    Velour red    Leather black

### Accessories



Steel sidemount

\* FIA approval 8855-1999 only valid in conjunction with the specified RECARO sidemount.



# ENTRY-LEVEL SEAT WITH POTENTIAL

Our recommendation for getting into GT, touring car and club sport – the RECARO Furious has a lightweight seat shell made from glass fiber reinforced plastic and belt slots for 4-, 5- or 6-point belts that make it the ideal RECARO product for embarking on a semi-professional or professional career in motor racing.



## // RECARO Furious

### Standard features

- + Seat shell made of glass fiber reinforced plastic (GRP)
- + Suitable for 4-, 5- or 6-point belts
- + Flame-retardant upholstery
- + Seat and backrest cushions replaceable
- + Lumbar cushions

### Accessories

- + Steel sidemount

<b>Weight</b>
approx. 7.5 kg
<b>FIA 8855-1999*</b>



### Upholstery variant



Velour black

### Accessories



Steel sidemount

Photo shows options

\* FIA approval 8855-1999 only valid in conjunction with the specified RECARO sidemount.



# AT HOME OFFROAD

It develops its true strength offroad – the RECARO Apex racing seat has pronounced lateral supports for excellent hold, above all on rough rally tracks. With its low weight of approx. 6.5 kg, it is particularly suited as an entry-level model.



Photo shows options

## // RECARO Apex

### Standard features

- + Seat shell made of glass fiber reinforced plastic (GRP)
- + Pronounced side bolsters
- + Suitable for 4-, 5- or 6-point belts
- + Flame-retardant upholstery
- + Seat and backrest cushions replaceable
- + Lumbar cushions

### Accessories

- + Steel sidemount

<b>Weight</b>
approx. 7.0 kg
<b>FIA 8855-1999*</b>



### Upholstery variant



Velour black

### Accessories



Steel sidemount

\* FIA approval 8855-1999 only valid in conjunction with the specified RECARO sidemount.



# TECHNICAL DATA

FIA approval 8855-1999



# TECHNICAL DATA

FIA approval 8862-2009 (Advanced Racing Seat)

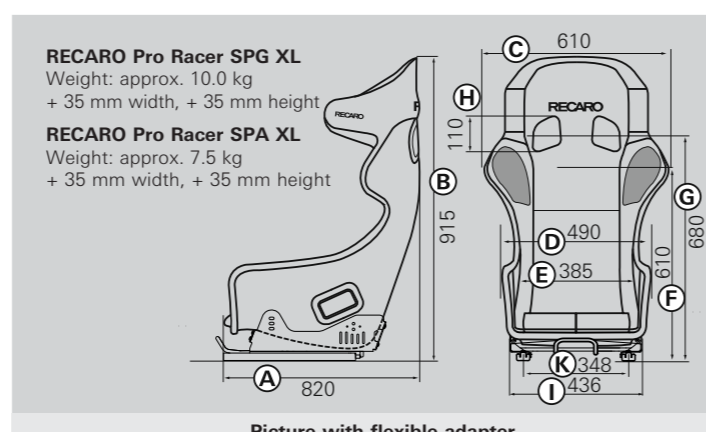
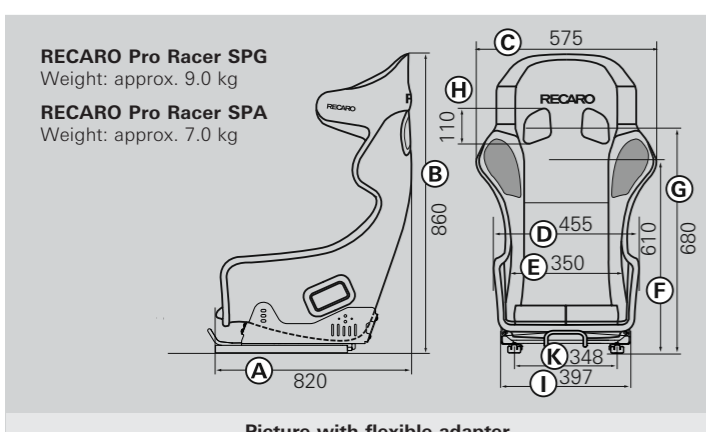
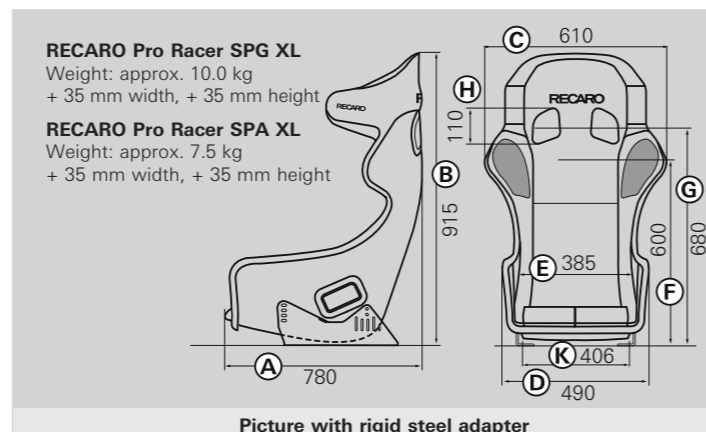
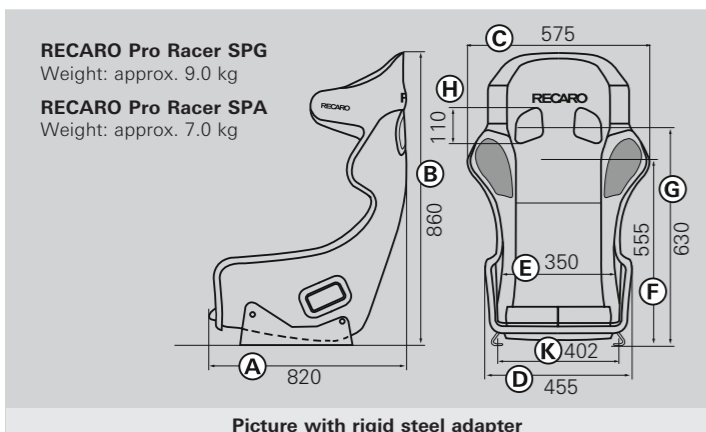
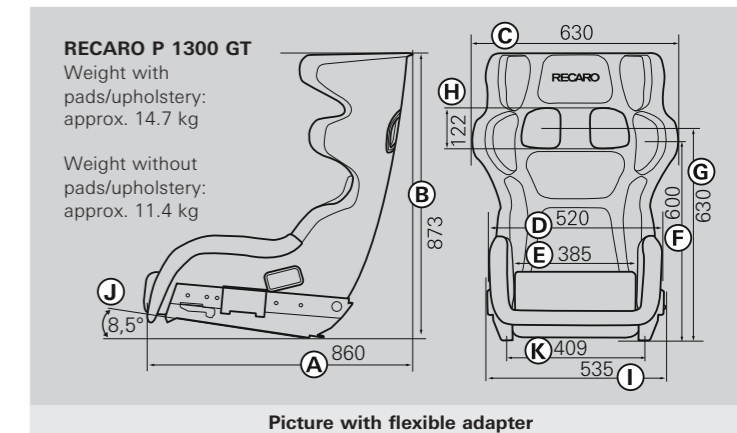
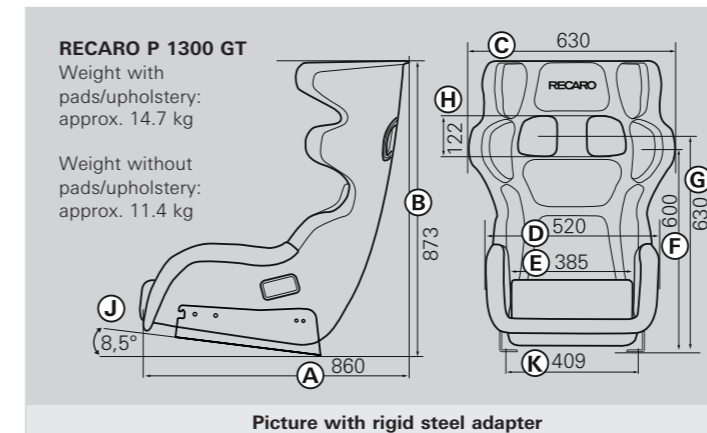
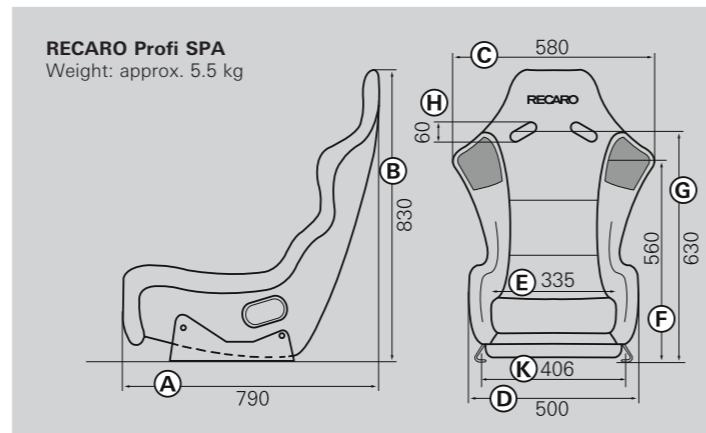
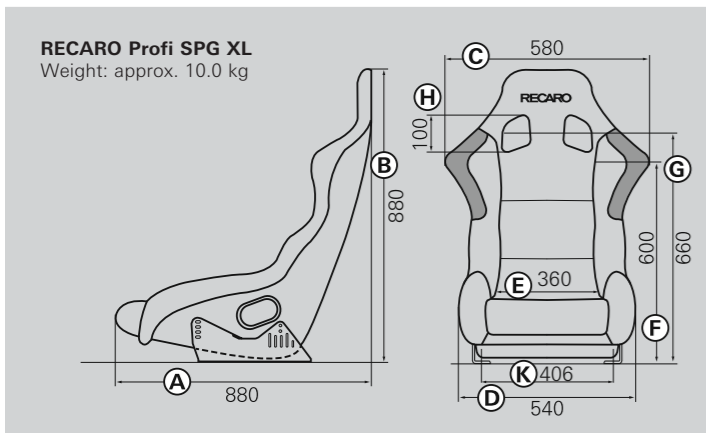
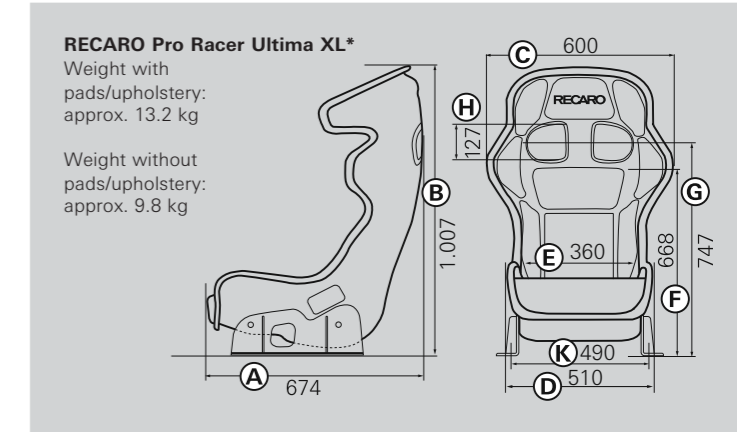
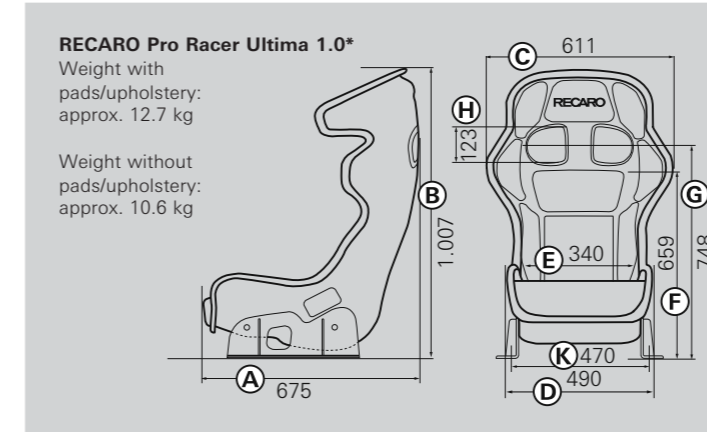
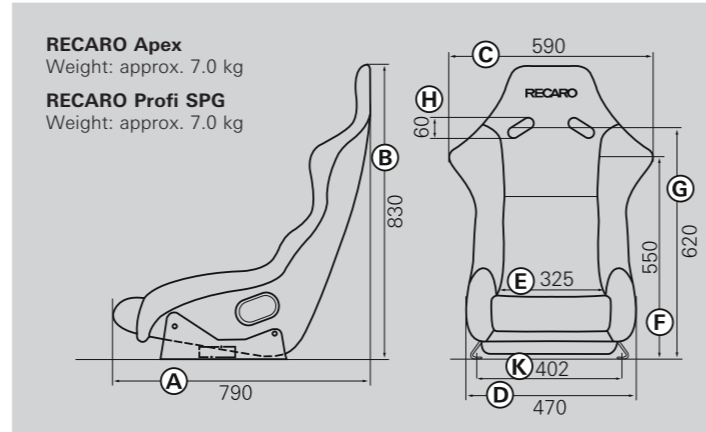
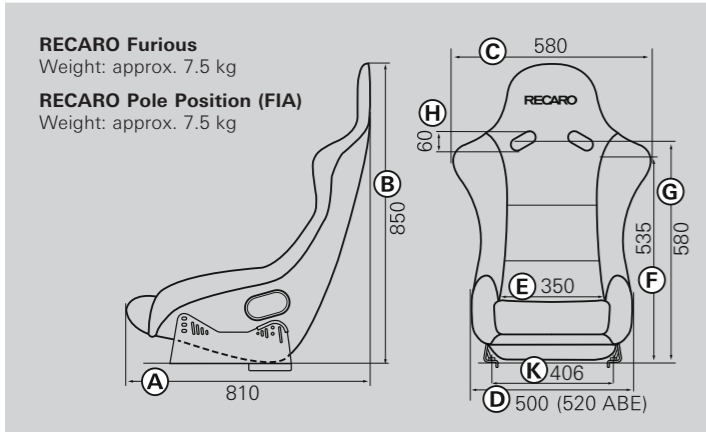

**KEY TO THE DIMENSIONS OF THE RECARO RACING SEATS:**

- Package dimensions:**
- A: Seat depth
  - B: Seat height
  - C: External shell dimension at shoulder
  - D: External shell dimension at seat cushion
  - I: Width of substructure
  - J: Tilt at mounting level
  - K: Track size (Mounting width for racing seats)

- Comfort dimensions:**
- E: Seating width
  - F: Height of shoulder support

- Belt slot:**
- G: Center belt slot
  - H: Height of belt slot

Dimensions in mm

\* In its outer shell measurement the RECARO Pro Racer Ultima 1.0 is wider than the RECARO Pro Racer Ultima XL, as it has a double-wall shell.

**NOTE:**

- The dimensions of the racing seats RECARO Furious, Pole Position (FIA), Apex, Profi SPG, Profi SPG XL, Profi SPA, Pro Racer SPG/SPA and Pro Racer SPG/SPA XL were determined in standard position (upper mounting point at front and lower mounting point at rear).
- The dimensions of the RECARO P 1300 GT were determined in the rearmost position.
- Weight: total shell weight (without mounted parts).
- RECARO racing shells can be individually fitted into nearly all racing cars. Not permitted in the area of the StVO – excluding FIA/ ASN licensed events.
- FIA approval 8855-1999 and 8862-2009 (Advanced Racing Seat) apply only in conjunction with specified sidemount.
- FIA homologation 8855-1999 only in combination with the associated adapter for the following RECARO racing seats: RECARO Furious, Pole Position FIA, Apex, Profi SPG, Profi SPG XL, Profi SPA, Pro Racer SPG, Pro Racer SPG XL, Pro Racer SPA, Pro Racer SPA XL.
- FIA homologation 8862-2009 (advanced racing seat) only in combination with the associated adapter for the following RECARO racing seats: RECARO Pro Racer Ultima 1.0, Pro Racer Ultima XL, P 1300 GT.
- The RECARO motorsport seats are made by hand to our highest quality standards. Due to this special manufacturing process, the lamination may in exceptional instances result in slight tolerances to the specified dimensions and weights.
- RECARO P 1300 GT: the adapters are geared in their design to a floor pan tilt of 8.5°. Depending on manufacturer and floor pan group, adaptations may be necessary when fitting (130 mm lengthways adjustment; angle of tilt variable by max. 3° during fitting)



# ACCESSORIES

FIA approval 8855-1999



<p><b>Aluminum sidemount</b></p> <p>For RECARO racing seats:  <b>RECARO Profi SPG XL</b>  <b>RECARO Pro Racer SPA XL</b>  <b>Weight: 1.1 kg</b></p>			
<p><b>Steel sidemount</b></p> <p>For RECARO racing seats:  <b>RECARO Pro Racer SPG XL</b>  <b>Weight: 2.6 kg</b></p>			
<p><b>Steel sidemount</b></p> <p>For RECARO racing seats:  <b>RECARO Apex</b>  <b>RECARO Profi SPG/SPA</b>  <b>RECARO Pro Racer SPG/SPA</b>  <b>Weight: 2.0 kg</b></p>			
<p><b>Steel sidemount</b></p> <p>For RECARO racing seats:  <b>RECARO Pole Position (FIA)</b>  <b>RECARO Furious</b>  <b>Weight: 3.1 kg</b></p>			
<p><b>Flexible adapter RECARO Pro Racer SPG/SPA</b></p> <p>For RECARO racing seats:  <b>RECARO Pro Racer SPG/SPA</b>  <b>Weight: 6.9 kg</b></p>			
<p><b>Flexible adapter RECARO Pro Racer SPG/SPA XL</b></p> <p>For RECARO racing seats:  <b>RECARO Pro Racer SPG/SPA XL</b>  <b>Weight: 7.7 kg</b></p>			

**High seat cushion**

For RECARO racing seat:  
**RECARO Pro Racer SPG/SPA**  
**Height: approx. 55 mm**  
**Upholstery: Velour black**

**HANS Protection**

Additional protection against wear of the HANS system.

# ACCESSORIES

FIA approval 8862-2009 (Advanced Racing Seat)



<p><b>Steel sidemount</b></p> <p>For RECARO racing seats:  <b>RECARO Pro Racer Ultima 1.0</b>  <b>RECARO Pro Racer Ultima XL</b></p>				
<p><b>Steel sidemount</b></p> <p>For RECARO racing seats:  <b>RECARO P 1300 GT</b>  <b>Weight: 4.1 kg</b></p>				
<p><b>Flexible adapter RECARO P 1300 GT*</b></p> <p>For RECARO racing seats:  <b>RECARO P 1300 GT</b>  <b>Weight: 10.7 kg</b></p>				

## Pad Kit for RECARO Pro Racer Ultima 1.0 and Ultima XL

**Pad Kit S**

For RECARO racing seats:  
**RECARO Pro Racer Ultima 1.0**  
**RECARO Pro Racer Ultima XL**  
 Pads for drivers of smaller build, 6-piece, without seat cushion

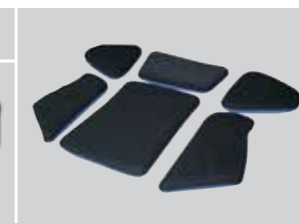

**Pad Kit L**

For RECARO racing seats:  
**RECARO Pro Racer Ultima 1.0**  
**RECARO Pro Racer Ultima XL**  
 Pads for drivers of larger build, 7-piece, with seat cushion



## Pad Kit for RECARO P 1300 GT

**Pad Kit S**

For RECARO racing seats:  
**RECARO P 1300 GT**  
 Pads for drivers of smaller build, 6-piece, without seat cushion

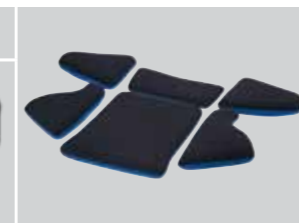

**Pad Kit L**

For RECARO racing seats:  
**RECARO P 1300 GT**  
 Pads for drivers of larger build, 5-piece, without seat cushion



**Lumbar pad**

For RECARO racing shells:  
**RECARO Pro Racer Ultima 1.0**  
**RECARO Pro Racer Ultima XL**  
**RECARO P 1300 GT**  
**Cover: Velour black**



**HANS protection**

Additional protection against wear of the HANS system.



**Site support pad**

For RECARO racing shells:  
**RECARO P 1300 GT**  
**Cover: Velour black**



**RECARO upholstery materials**

**Velour:**  
 Rugged and easy-to-care-for fabric. The upholstery materials used for the racing seats provides a higher degree of safety than required by the FIA standard. Upholstery material has been tested for flame retardance according to the FMVSS 302/ISO 3795 regulations

**Leather:**  
 RECARO leather is a high-quality natural product for exacting requirements for the vehicle interior.

\* The sidemounts are designed for a ground angle of 8.5°. Adjustments may be required during installation depending on the manufacturer and ground group.



# RECARO SYMBOLS

## USE



Seat for GT vehicles



Seat for touring cars



Seat for rally vehicles

## CUSTOM DRIVER COMFORT



Flexible sidemount (fore-aft adjustment), ideal for racing use with change of driver



Replaceable pads (S/M/L), individually adjustable to the driver's build



XL seat – ideal for large persons



Anatomical seat contours for ideal adaptation to personal comfort needs

## LIGHTWEIGHT CONSTRUCTION



Very light racing seat. Seat shell made of Carbon-Kevlar® composite (CFK).



Seat shell made of carbon composite

## SAFETY



Tested according to FIA standard 8862-2009 (Advanced Racing Seat)



FIA homologation for 10 years



Racing seat optimized for the HANS system



Racing seat with shock-absorbing foam



FIA approval 8855-1999 Upholstery material has been tested for flame retardance according to the FMVSS 302 regulations



FIA approval 8862-2009 Upholstery material has been tested for flame retardance according to the ISO 3795 regulations



FIA-approved racing seat or sidemount

\* FIA approval 8862-2009 (Advanced Racing Seat) only in conjunction with specified sidemounts.

RECARO Automotive Seating  
Stuttgarter Straße 73  
73230 Kirchheim/Teck  
Germany

Phone: +49 7021 93-5000  
Fax: +49 7021 93-5339

Email: [info@recaro-automotive.com](mailto:info@recaro-automotive.com)  
Internet: [www.recaro-automotive.com](http://www.recaro-automotive.com)



ID NO.: 7223573 - OCTOBER 2014 - FACT/DIE WORTWERKSTATT  
RECARO® Pole Position® are registered trademarks of RECARO Beteiligungs-GmbH.  
We reserve the right to make changes to the technology, form, color, and design of our products. We accept no liability for printing errors.